

LCD Colour TV

Operating Instructions

Start-up Guide

Operating the TV

Using Optional Equipment

Using Menu Functions

Additional Information

BRAVIA

Introduction

Thank you for choosing this Sony product.
Before operating the TV, please read this manual thoroughly and retain it for future reference.

The illustrations used in this manual are of the KLV-32BX320 unless otherwise stated.

Notice for customers in India

Attach the supplied plug adaptor.

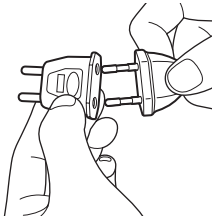

Notice for customers in South Africa

The Euro/South Africa converter plug should be fitted as follows.

- 1 Insert the power supply or CEE7 plug in to the converter plug.
- 2 Use an appropriate screwdriver to attach the screw tightly without damaging the screw head.
- 3 **TEST:** Grip the converter plug, and pull the VDE cord set/transformer to ensure it is fully secure, if not then increase the torque setting and further tighten.
Re-test.

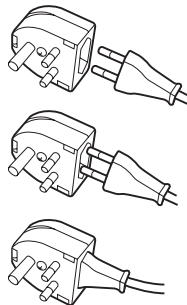

The converter plug is now ready for use.

Trademark information

- HDMI, the HDMI Logo, and High-Definition Multimedia Interface are trademarks or registered trademarks of HDMI Licensing LLC in the United States and other countries.
- Manufactured under license from Dolby Laboratories. Dolby and the double-D symbol are trademarks of Dolby Laboratories.
- DivX[®], DivX Certified[®] and associated logos are trademarks of DivX, Inc. and are used under license.

ABOUT DIVX VIDEO: DivX[®] is a digital video format created by DivX, Inc. This is an official DivX Certified[®] device that plays DivX video. Visit divx.com for more information and software tools to convert your files into DivX video.

ABOUT DIVX VIDEO-ON-DEMAND: This DivX Certified[®] device must be registered in order to play purchased DivX Video-on-Demand (VOD) movies. To obtain your registration code, locate the DivX VOD section in your device setup menu. Go to vod.divx.com for more information on how to complete your registration.

- “BRAVIA” and BRAVIA are trademarks of Sony Corporation.

HDMI[™]
HIGH-DEFINITION MULTIMEDIA INTERFACE

DOLBY[®]
DIGITAL

DIVX[™]
HD

Location of the identification label

Labels for Model No. and Power Supply rating (in accordance with applicable safety regulation) are located on the rear of the TV.

IMPORTANT INFORMATION

If a television is not positioned in a sufficiently stable location, it can be potentially hazardous due to falling. Many injuries, particularly to children, can be avoided by taking simple precautions such as:

- Using cabinets or stands recommended by the manufacturer of the television.
- Only using furniture that can safely support the television.
- Ensuring the television is not overhanging the edge of the supporting furniture.
- Not placing the television on tall furniture (for example, cupboards or bookcases) without anchoring both the furniture and the television to a suitable support.
- Not standing the televisions on cloth or other materials placed between the television and supporting furniture.
- Educating children about the dangers of climbing on furniture to reach the television or its controls.

Table of Contents

Start-up Guide

Checking the accessories	6
1: Attaching the stand.....	6
2: Connecting an antenna/cable/VCR	7
3: Preventing the TV from toppling over.....	7
4: Performing the initial set-up.....	8
Watching TV	8
Adjusting the viewing angle of the TV (NX520 models only).....	9
Detaching the stand from the TV.....	9
Safety information	10
Precautions	11

Operating the TV

Overview of the remote	12
Overview of the TV buttons and indicators.....	14

Using Optional Equipment

Connecting optional equipment.....	15
Viewing pictures from the connected equipment.....	16
Viewing Twin Picture	17
Viewing PIP (Picture in Picture).....	17

Using Menu Functions

Navigating through menus	18
Using the Favourites	18
Playing back photo/music/video via USB.....	19
Listening to the FM Radio	22
Using BRAVIA Sync with Control for HDMI	23
Settings adjustment.....	24
Picture	24
Sound.....	25
Screen.....	27
Channel Set-up	29
Parental Lock	30
Set-up.....	31
Eco	33

Additional Information

Installing the accessories (Wall-Mount Bracket)	34
TV installation dimensions table.....	35
Screw and hook locations diagram/table	36
Troubleshooting	37
Specifications	39

Before operating the TV, please read "Safety information" (page 10). Retain this manual for future reference.

Start-up Guide

Checking the accessories

Stand (1) and screws (7) (for KLV-40/32NX520 (8))

Remote RM-GA020 (1)

Size AA batteries (R6 type) (2)

To insert batteries into the remote

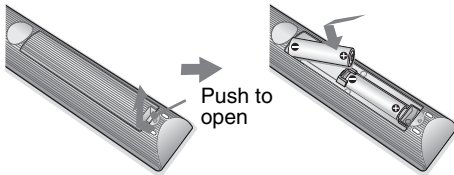

► KLV-22CX320/KLV-22BX320

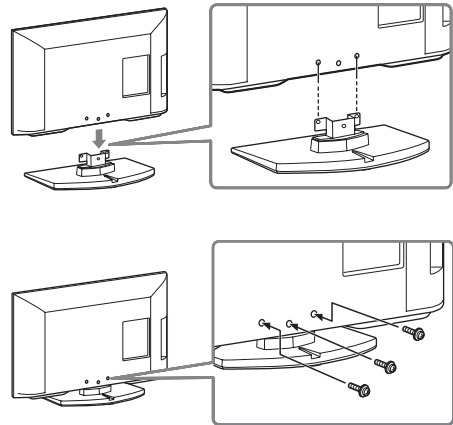

1: Attaching the stand

- Refer to the supplied stand leaflet for proper attachment for some TV models.
- For best picture quality, do not expose the screen to direct illumination or sunlight.
- If the TV is brought directly from a cold to a warm location, or is placed in a very damp room, or is placed in a room in which heating has just been turned on, moisture may condense on the surface or inside the TV. Should this occur, turn off the TV and leave the TV off until the moisture evaporates, and then the TV can be used. If you notice moisture condensation between the glass panel and the LCD, turn on the TV and the condensation will evaporate after the TV has warmed up.

► KLV-40/32NX520/KLV-40/32CX420/KLV-40BX420/KLV-32/26CX320/KLV-32/26BX320/KLV-32BX311

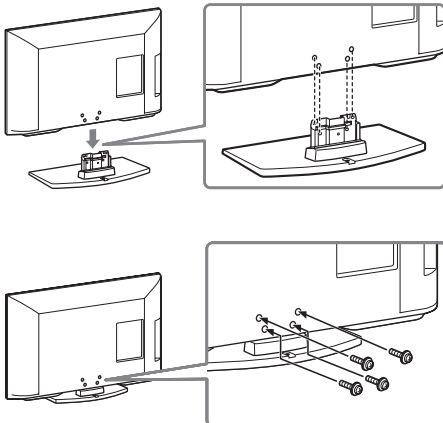

- Fix the TV to the stand according to the arrow marks  that guide the screw holes using the supplied screws.
- This TV is very heavy, so two or more people should place the TV onto the stand.
- If using an electric screwdriver, set the tightening torque at approximately 1.5 N·m (15 kgf·cm).
- Ensure the AC power cord is away from screw holes during stand installation to avoid damage to the AC power cord.

2: Connecting an antenna/cable/VCR

 • Connecting cables are not supplied.

Connecting an antenna/cable

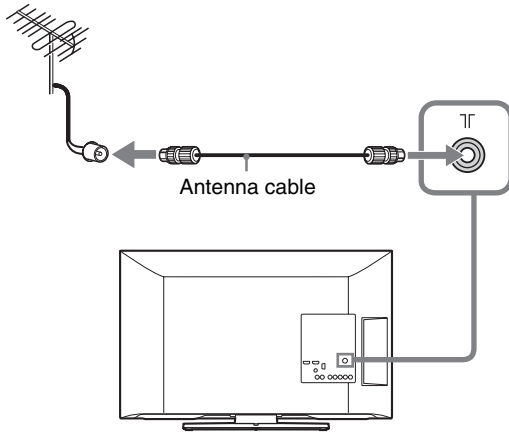

Connecting an antenna/cable and VCR

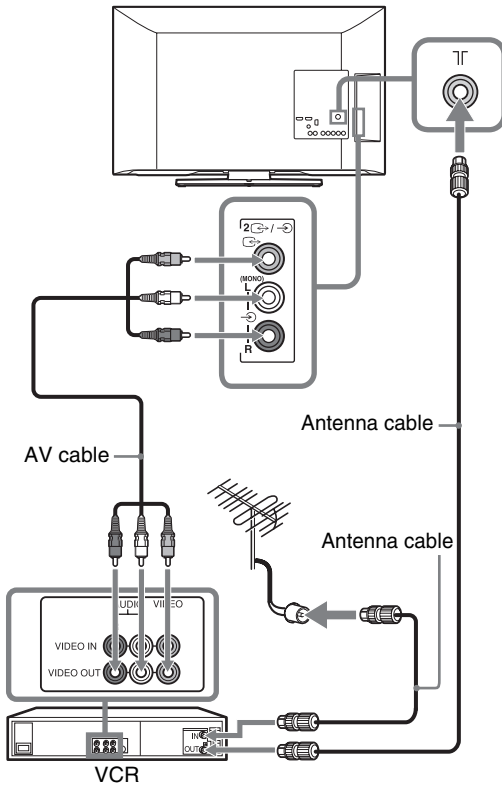

3: Preventing the TV from toppling over

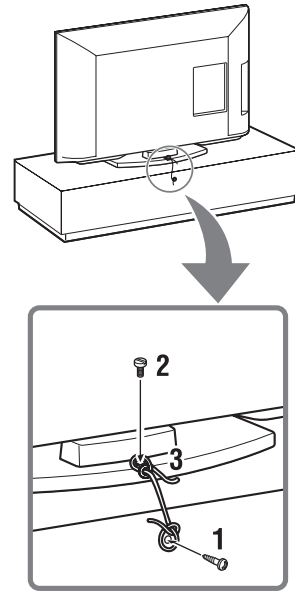

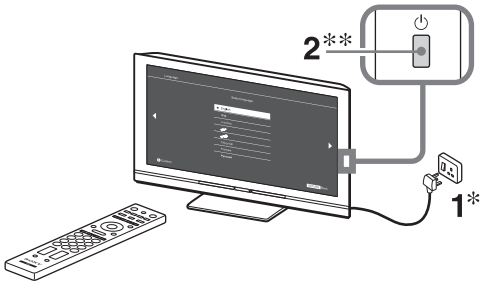

- 1** Install a wood screw (4 mm in diameter, not supplied) in the TV stand.
 - 2** Install a machine screw (M4 × 16, not supplied) into the screw hole of the TV.
 - 3** Tie the wood screw and the machine screw with a strong cord (not supplied).
-  • An optional Sony support belt kit is used to secure the TV. Contact your nearest Sony service centre to purchase a kit. Have your TV model name ready for reference.

4: Performing the initial set-up



* The shapes of AC power plug and AC power outlet differ depending on the region.

**When the TV is in standby mode (the  (standby) indicator on the TV front panel is red), press  on the remote to turn on the TV.

3





Follow the instructions on the screen.

“Location”: Select “Home” for the best TV settings to use the TV in the home.

“Programme Sorting”: If you want to change the order of channels, follow the steps in “Programme Sorting” (page 29). Press **HOME** to exit.

- You can also tune channels manually (page 29).
- Language options vary depending on model.

Watching TV

- 1 Press  on the TV to turn on the TV.
- 2 Press the number buttons or **PROG +/-** to select a TV channel.
- 3 Press  +/- to adjust the volume.

Adjusting the viewing angle of the TV (NX520 models only)

This TV can be adjusted within the angles shown below.

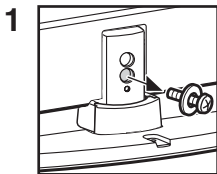
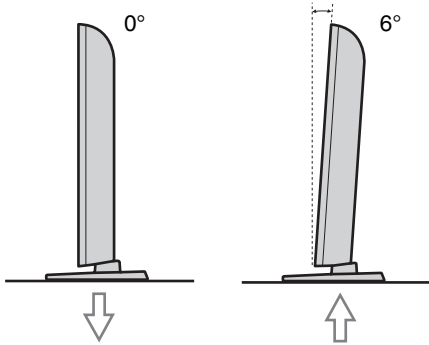

1 Remove screw as shown.

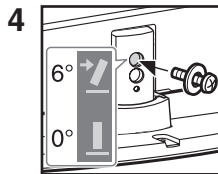

4 Install screw into the top screw hole of the Table-Top Stand.

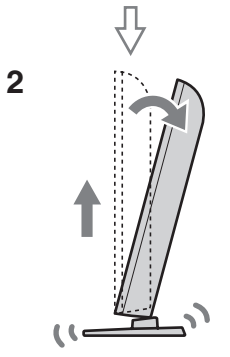

2 Lift up and tilt.

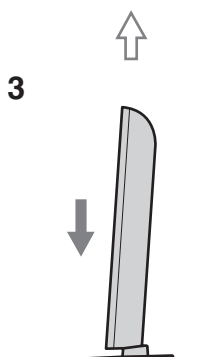

3 Slide in.

• To return to 0°, reverse the above procedure.

Detaching the stand from the TV

• Do not remove the stand for any reason other than to wall-mount the TV.

► KLV-40/32NX520/KLV-40/32CX420/KLV-40B420/KLV-32/26CX320/KLV-32/26B320/KLV-32B311

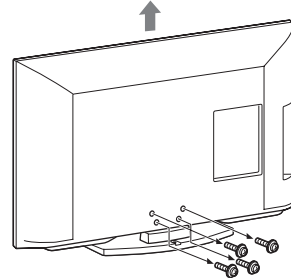

► KLV-22CX320/KLV-22B320

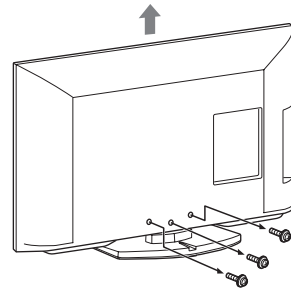

Safety information

Installation/Set-up

Install and use the TV set in accordance with the instructions below in order to avoid any risk of fire, electrical shock or damage and/or injuries.

Installation

- The TV set should be installed near an easily accessible AC power outlet.
- Place the TV set on a stable, level surface to avoid it from falling down and cause personal injury or damage to the TV.
- Only qualified service personnel should carry out wall installations.
- For safety reasons, it is strongly recommended that you use Sony accessories, including:
 - KLV-40NX520/40CX420/40BX420/32NX520/32CX420/32CX320/32BX320/32BX311:
Wall-mount bracket SU-WL50B
 - KLV-26CX320/26BX320/22CX320/22BX320:
Wall-mount bracket SU-WL100
- Be sure to use the screws supplied with the Wall-mount bracket when attaching the mounting hooks to the TV set. The supplied screws are designed as indicated by illustration when measured from the attaching surface of the mounting hook. The diameter and length of the screws differ depending on the Wall-mount bracket model.
Use of screws other than those supplied may result in internal damage to the TV set or cause it to fall, etc.

Min. ~ 26 TV: 6.5 ~ 10mm
32 TV ~ Max.: 8 ~ 12mm

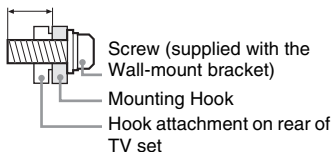

Transporting

- Before transporting the TV set, disconnect all cables.
- Two or more people are needed to transport a large TV set.

- When transporting the TV set by hand, hold it as shown below. Do not put stress on the LCD panel.



KLV-26/22CX320/
KLV-26/22BX320

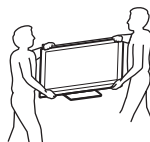

KLV-40/32NX520/
KLV-40/32CX420/
KLV-40BX420/
KLV-32CX320/
KLV-32BX320/
KLV-32BX311

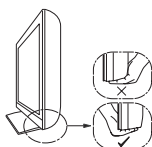

- When lifting or moving the TV set, hold it firmly from the bottom.
- When transporting the TV set, do not subject it to jolts or excessive vibration.
- When transporting the TV set for repairs or when moving, pack it using the original carton and packing material.

Ventilation

- Never cover the ventilation holes or insert anything in the cabinet.
- Leave space around the TV set as shown below.
- It is strongly recommended that you use a Sony wall-mount bracket in order to provide adequate air-circulation.

Installed on the wall

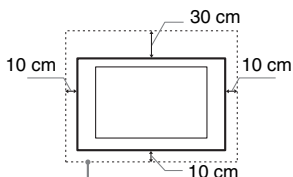

Leave at least this space around the set.

Installed with stand

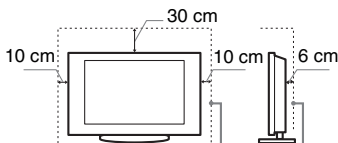

Leave at least this space around the set.

- To ensure proper ventilation and prevent the collection of dirt or dust:
 - Do not lay the TV set flat, install upside down, backwards, or sideways.
 - Do not place the TV set on a shelf, rug, bed or in a closet.
 - Do not cover the TV set with a cloth, such as curtains, or items such as newspapers, etc.
 - Do not install the TV set as shown below.

Air circulation is blocked.

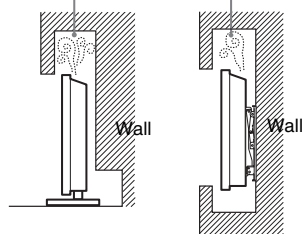

AC power cord

Handle the AC power cord and outlet as follows in order to avoid any risk of fire, electrical shock or damage and/or injuries:

- The shape of AC power plug, which is supplied with the TV set, varies depending on the regions. Be sure to connect the appropriate supplied AC power cord with the plug that fits into the AC power outlet.
- Use only Sony supplied AC power cords, not those of other brands.
- Insert the plug fully into the AC power outlet.
- Operate the TV set on a 110-240 V AC supply only.
- When wiring cables, be sure to unplug the AC power cord for your safety and take care not to catch your feet on the cables.
- Disconnect the AC power cord from the AC power outlet before working on or moving the TV set.
- Keep the AC power cord away from heat sources.
- Unplug the AC power plug and clean it regularly. If the plug is covered with dust and it picks up moisture, its insulation may deteriorate, which could result in a fire.

Notes

- Do not use the supplied AC power cord on any other equipment.
- Do not pinch, bend, or twist the AC power cord excessively. The core conductors may be exposed or broken.
- Do not modify the AC power cord.
- Do not put anything heavy on the AC power cord.
- Do not pull on the AC power cord itself when disconnecting the AC power cord.
- Do not connect too many appliances to the same AC power outlet.
- Do not use a poor fitting AC power outlet.

Prohibited Usage

Do not install/use the TV set in locations, environments or situations such as those listed below, or the TV set may malfunction and cause a fire, electrical shock, damage and/or injuries.

Location:

- Outdoors (in direct sunlight), at the seashore, on a ship or other vessel, inside a vehicle, in medical institutions, unstable locations, near water, rain, moisture or smoke.
- If the TV is placed in the changing room of a public bath or hot spring, the TV may be damaged by airborne sulfur, etc.

Environment:

- Places that are hot, humid, or excessively dusty; where insects may enter; where it might be exposed to mechanical vibration, near flammable objects (candles, etc). The TV set shall not be exposed to dripping or splashing and no objects filled with liquids, such as vases, shall be placed on the TV.
- Do not place the TV in a humid or dusty space, or in a room with oily smoke or steam (near cooking tables or humidifiers). Fire, electric shock, or warping may result.

Situation:

- Do not use when your hands are wet, with the cabinet removed, or with attachments not recommended by the manufacturer. Disconnect the TV set from AC power outlet and antenna during lightning storms.
- Do not install the TV so that it sticks out into an open space. Injury or damage from a person or object bumping into the TV may result.

Broken pieces:

- Do not throw anything at the TV set. The screen glass may break by the impact and cause serious injury.
- If the surface of the TV set cracks, do not touch it until you have unplugged the AC power cord. Otherwise electric shock may result.
- Do not subject the LCD screen to any strong impact or shock. The screen glass may crack or shatter and cause injury.

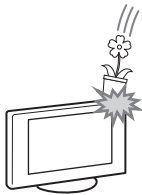

When not in use

- If you will not be using the TV set for several days, the TV set should be disconnected from the AC power for environmental and safety reasons.
- As the TV set is not disconnected from the AC power when the TV set is just turned off, pull the plug from the AC power outlet to disconnect the TV set completely.
- However, some TV sets may have features that require the TV set to be left in standby to work correctly.

For children

- Do not allow children to climb on the TV set.
- Keep small accessories out of the reach of children, so that they are not mistakenly swallowed.

If the following problems occur...

Turn off the TV set and unplug the AC power cord immediately if any of the following problems occur. Ask your dealer or Sony service centre to have it checked by qualified service personnel.

When:

- AC power cord is damaged.
- Poor fitting of AC power outlet.
- TV set is damaged by being dropped, hit or having something thrown at it.
- Any liquid or solid object falls through openings in the cabinet.

About LCD Monitor Temperature

When the LCD Monitor is used for an extended period, the panel surrounds become warm. You may feel hot when touching there by the hand.

Precautions

Viewing the TV

- View the TV in moderate light, as viewing the TV in poor light or during long period of time, strains your eyes.
- When using headphones, adjust the volume so as to avoid excessive levels, as hearing damage may result.

LCD Screen

- Although the LCD screen is made with high-precision technology and 99.99% or more of the pixels are effective, black dots may appear or bright points of light (red, blue, or green) may appear constantly on the LCD screen. This is a structural property of the LCD screen and is not a malfunction.
- Do not push or scratch the front filter, or place objects on top of this TV set. The image may be uneven or the LCD screen may be damaged.
- If this TV set is used in a cold place, a smear may occur in the picture or the picture may become dark. This does not indicate a failure. These phenomena disappear as the temperature rises.
- Ghosting may occur when still pictures are displayed continuously. It may disappear after a few moments.
- The screen and cabinet get warm when this TV set is in use. This is not a malfunction.
- The LCD screen contains a small amount of liquid crystal. Some fluorescent tubes used in this TV set also contain mercury. Follow your local ordinances and regulations for disposal.

Handling and cleaning the screen surface/cabinet of the TV set

Be sure to unplug the AC power cord connected to the TV set from AC power outlet before cleaning.

To avoid material degradation or screen coating degradation, observe the following precautions.

- To remove dust from the screen surface/cabinet, wipe gently with a soft cloth. If dust is persistent, wipe with a soft cloth slightly moistened with a diluted mild detergent solution.
- Do not spray water or detergent directly on the TV set. It may drip to the bottom of the screen or exterior parts, and may cause a malfunction.
- Never use any type of abrasive pad, alkaline/acid cleaner, scouring powder, or volatile solvent, such as alcohol, benzene, thinner or insecticide. Using such materials or maintaining prolonged contact with rubber or vinyl materials may result in damage to the screen surface and cabinet material.
- Periodic vacuuming of the ventilation openings is recommended to ensure to proper ventilation.
- When adjusting the angle of the TV set, move it slowly so as to prevent the TV set from moving or slipping off from its table stand.

Optional Equipment

Keep optional components or any equipment emitting electromagnetic radiation away from the TV set. Otherwise picture distortion and/or noisy sound may occur.



(Caution about handling the remote control)

Notes

- Observe the correct polarity when inserting batteries.
- Do not use different types of batteries together or mix old and new batteries.
- Dispose of batteries in an environmentally friendly way. Certain regions may regulate the disposal of batteries. Please consult your local authority.
- Handle the remote with care. Do not drop or step on it, or spill liquid of any kind onto it.
- Do not place the remote in a location near a heat source, a place subject to direct sunlight, or a damp room.

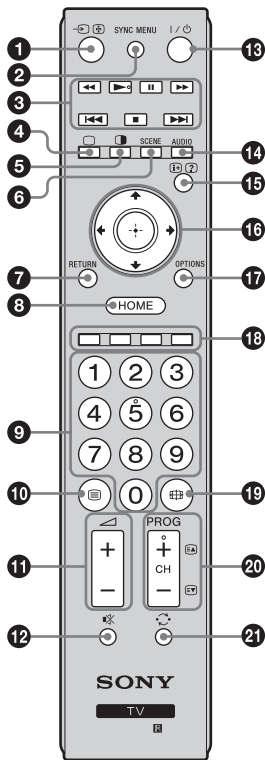
Overview of the remote



 The number 5, , **PROG +** and **AUDIO** buttons have tactile dots. Use the tactile dots as references when operating the TV.

- 1  **Input select / Text hold**
 - Displays the connected equipment list and selects the input source (page 16).
 - In Text mode: Holds the current page.
- 2 **SYNC MENU**

Press to display the BRAVIA Sync Menu and then select connected HDMI equipment from “HDMI Device Selection”.

The following options can be selected from BRAVIA Sync Menu:

“**Device Control**”: Use the “Device Control” menu to operate equipment that is compatible with Control for HDMI. Select options from “Home (Menu)”, “Options” and “Content List” to operate the equipment.

“**Speakers**”: Selects “TV Speakers” or “Audio System” to output the TV’s sound from the TV speakers or connected audio equipment.

“**TV Control**”: Use the “TV Control” menu to operate the TV from the “HOME (Menu)” or “Options” menu.

“**Return to TV**”: Selects this option to return to TV programme.
- 3 

You can operate the BRAVIA Sync-compatible equipment that is connected to the TV. Some other buttons on the remote control may also operate BRAVIA Sync equipment.
- 4  **TV mode**

Exit Text mode, or switches to a TV display when displaying external input.
- 5  **Twin Picture / PIP (page 17)**
- 6 **SCENE – Scene Select mode**

Press to display the “Scene Select” menu. When you select the desired scene option, the optimum sound and picture quality for selected scene are automatically set. The options you can select may vary. Unavailable options are greyed out.

“**Auto**”: Delivers optimum picture and sound quality which is automatically set according to input source. There may not be any effect depending on the connected equipments.

“**General**”: Current user settings.

“**Photo**”: Delivers picture that reproduces the texture and colour of a printed photo.

“**Music**”: Delivers dynamic and clear sound effects like at a concert.

“**Cinema**”: Delivers theatre-like picture and dynamic sound.



“**Game**”: Delivers the best picture and sound quality for fullest game playing enjoyment.

“**Graphics**”: Delivers clearer detailed pictures to reduce fatigue for prolonged viewing.

“**Sports**”: Delivers realistic picture with surround sound like in a stadium.
- 7 **RETURN**
 - Returns to the previous screen of any displayed menu.
 - When playing a photo/music/video file: Press to stop the playback (the display returns to the file or thumbnail view).
- 8 **HOME**

Displays or cancels the menu.
- 9 **Number buttons**
 - Selects channels. For channel numbers 10 and above, enter the next digit quickly (page 29).
 - In Text mode: Enters the three digit page number to select the page.
- 10  **Text**

In Text mode: Displays Text broadcast.

Each time you press , the display changes cyclically as follows:
Text → Text over the TV picture (mix mode) → No Text (exit the Text service)
- 11  **Volume**

Adjusts volume.
- 12  **Mute**

Press to mute the sound. Press again to restore the sound.
- 13  **TV standby**

Press to turn the TV on or to switch to standby mode.
- 14 **AUDIO – Dual Sound (page 26)**

- 15 – **Info / Text reveal**
 - Displays information. Press once to display information about the programme/ input you are viewing. Press again to remove the display from the screen.
 - In Text mode: Reveals hidden information (e.g. answers to a quiz).
- 16 – **Item select / Enter**
 - Selects or adjusts items.
 - Confirms selected items.
 - When playing a photo file: Press to select the previous file. Press to select the next file.
 - When playing a music/video file: Press to pause/start the playback. Press and hold to fast forward/fast reverse, then release the button at the point where you want to resume playback.
- 17 **OPTIONS**

Press to display a list that contains shortcuts to some setting menus. The listed options vary depending on the current input and content.
- 18 **Coloured buttons**

When the coloured buttons are available, an operation guide appears on the screen.
- 19 – **Wide Mode**

Changes the picture size. Press repeatedly to select the desired wide mode (page 13).
- 20 **PROG/CH +/-/EA/EB**
 - Selects the next (+) or previous (-) channel.
 - In Text mode: Selects the next (EA) or previous (EB) page.
- 21 – **Previous channel**

Returns to the previous channel or input watched (for more than 15 seconds).

To change the Wide Mode

For TV, Video, Component or HDMI (except PC input)

	Enlarges the centre portion of the picture. The left and right edges of the picture are stretched to fill the 16:9 screen.
	Displays the 4:3 picture in its original size. Side bars are shown to fill the 16:9 screen.
	Stretches the 4:3 picture horizontally to fill the 16:9 screen.
	Displays cinematic (letter box format) broadcasts in the correct proportions.

* Parts of the top and bottom of the picture may be cut off.

- You cannot select “Normal” for HD signal source pictures.

PC or HDMI PC Input (PC timing)

	Displays the picture in its original pixel size. Bars are shown at the top, bottom, and both sides for small picture.
	Stretches the original picture to fill the screen vertically, keeping its original horizontal-to-vertical aspect ratio.
	Stretches the Full 1 picture horizontally to fill the 16:9 screen.

- Some options may not be available depending on the PC input signal.

Overview of the TV buttons and indicators

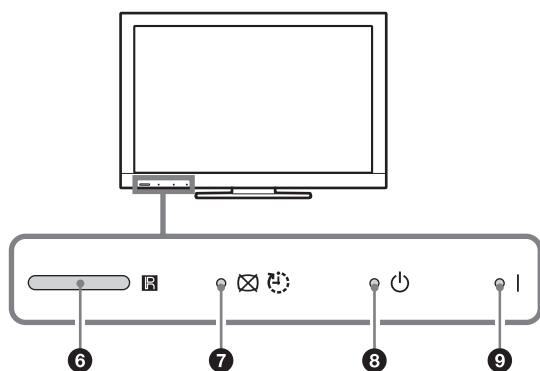
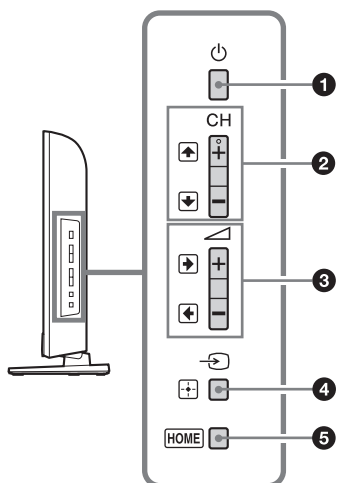

- 1** – **Power**
 Press to turn the TV on or to switch to standby mode.
 - To disconnect the TV from the AC power completely, pull the plug from the AC power outlet.
 - 2** **CH +/-**
 - Selects the next (+) or previous (-) channel.
 - In TV menu: Moves through the options up () or down ()
 - 3**
 - Increases (+) or decreases (-) the volume.
 - In TV menu: Moves through the options right () or left ()
 - 4** – **Input select / Enter**
 - Displays the connected equipment list and selects the input source (page 16).
 - In TV menu: Selects the menu or option, and confirms the setting.
 - 5** **HOME**
 Displays or cancels the menu.
 - 6** – **Remote sensor / Light sensor**
 Receives IR signals from the remote. Senses room light level and adjusts the screen brightness accordingly. Do not put anything over the sensor, doing so may affect its function. (KLV-40/32/26/22CX420/320 only)
 - 7** – **Picture Off / Timer indicator**
 - Lights up in green when you select “Picture Off” (page 33).
 - Lights up in amber when you set the timer (page 31) or “Picture Frame” (page 19).
 - 8** – **Standby indicator**
 Lights up in red when the TV is in standby mode.
 - 9** – **Power indicator**
 - Lights up in green when the TV is turned on.
 - Flashes while the remote is being operated.
- Make sure that the TV is completely turned off before unplugging the AC power cord. Unplugging the AC power cord while the TV is turned on may cause the indicator to remain lit or may cause the TV to malfunction.
- The **CH +** button has a tactile dot. Use it as a reference when operating the TV.

Using Optional Equipment

Connecting optional equipment

You can connect a wide range of optional equipment to your TV.

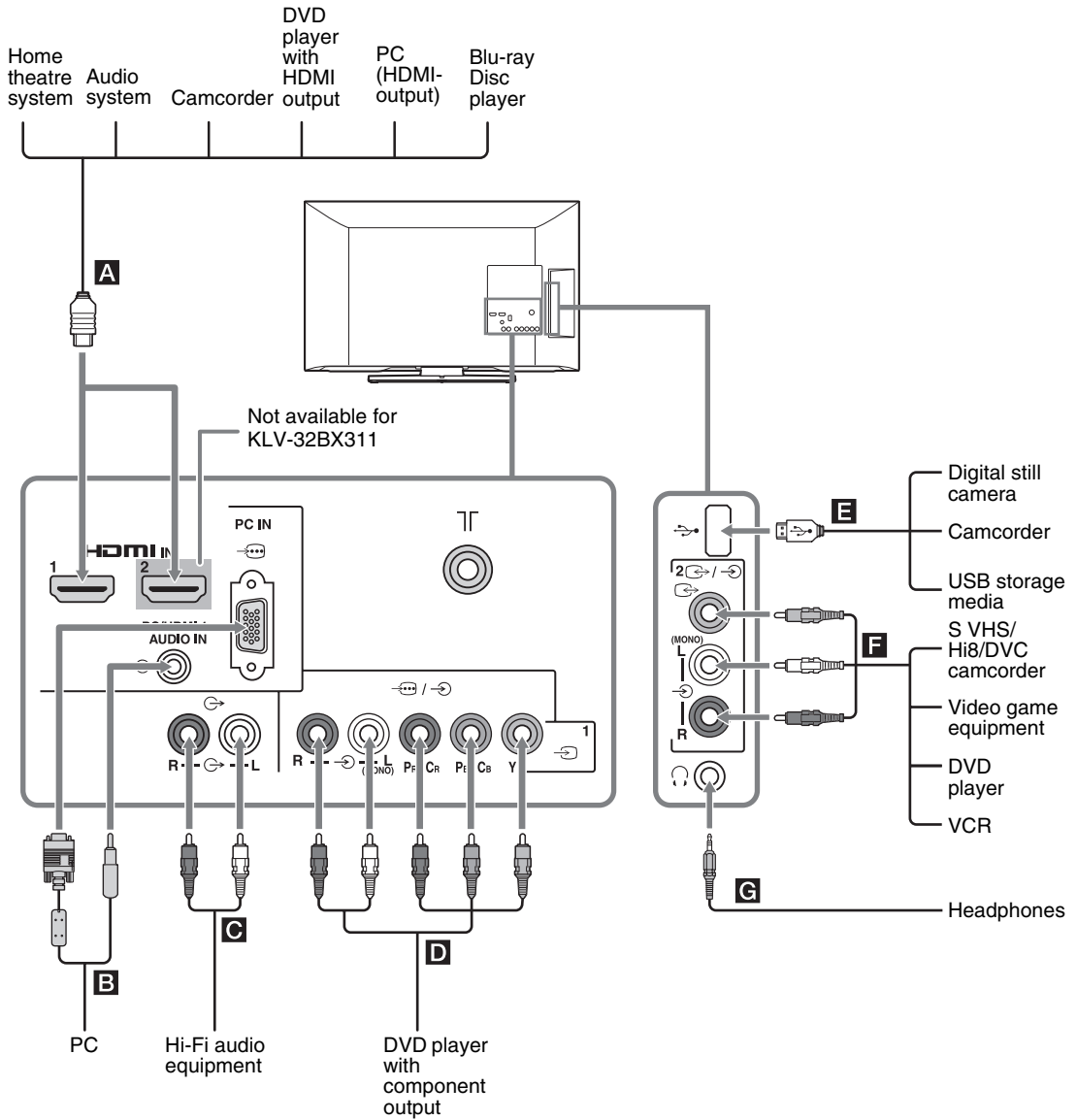

Viewing pictures from the connected equipment

Turn on the connected equipment, then press / to display the connected equipment list. Press / to select the desired input source, then press . (The highlighted item is selected if 2 seconds pass without any operation after pressing /.) When the input source is set to "Skip" in the "Video Labels" under the "AV Set-up" menu (page 31), that input is greyed out in the list.

- Press / on the TV to display the connected equipment list and select the desired input source. You can also press / to select the desired input source. Then wait for 2 seconds to display the selected input source.

Jacks/ Input symbol on screen	Description
A HDMI IN 1 or 2* HDMI 1 or HDMI 2* * Not available for KLV-32BX311	Connect to the HDMI IN 1 or 2* jack if the equipment has an HDMI jack. The digital video and audio signals are input from the equipment. In addition, when you connect the equipment that is compatible with Control for HDMI, communication with the connected equipment is supported. See page 32 to set up this communication. If the equipment has a DVI jack, connect the DVI jack to the HDMI IN 1 jack through a DVI - HDMI adaptor interface (not supplied), and connect the equipment's audio out jack to the PC/HDMI 1 AUDIO IN jack in the PC IN jacks (the PC/HDMI 1 AUDIO IN jack is used as the audio in jack for both the PC IN and HDMI IN 1 jacks). • The HDMI jacks only support the following video inputs: 480i, 480p, 576i, 576p, 720p, 1080i, 1080p and 1080/24p. • The HDMI jacks can support PC timing in HDMI PC mode. See page 28 for supported PC input signal. • Be sure to use only an authorized HDMI cable bearing the HDMI logo. We recommend that you use a Sony HDMI cable (high speed type).
B PC IN / PC	Connect to the PC IN jack and the audio jack . It is recommended to use a PC cable with ferrite core.
C	You can listen to TV sound on the connected Hi-Fi audio equipment.
D / or Component or Video 1	Connect to the component jacks and the audio jacks /. For better picture quality, component connection is recommended if your DVD player has a component video output. When using the component video jack as the video jack 1, select "Video 1" in the "Video 1/Component Input" menu (page 31). • You cannot use the component video jack and the video jack 1 at the same time.
E	You can enjoy photo/music/video files stored in a Sony digital still camera, camcorder or USB storage device (page 19).
F / 2 Video 2	Connect to the video jack 2 and the audio jacks 2. If you connect mono equipment, connect to the L (MONO) jack 2. When using the video jack as output jacks, select "Output" in the "Video 2 Input/Output" menu (page 31). Connect to the video output jack 2 to record the image from the TV. To turn off the sound of the TV speakers, set "Speakers" to "Audio System" (page 26). • The monitor output jacks cannot support Component, HDMI and PC signals source pictures, also audio signal for sound.
G Headphones	You can listen to TV sound through headphones.

Viewing Twin Picture

You can view two pictures (in Component and HDMI input mode) on the screen simultaneously. Connect the optional equipment (page 15), and make sure that images from the equipment appear on the screen (page 16).

1 Press **□**.

Two pictures are displayed simultaneously.



Twin Picture Availability

In Left Window	In Right Window
Component HDMI 1/2* (except PC input mode)	TV programme or Video 1/2

* Not available for KLV-32BX311

2 Press **↔** to select active picture.

3 In right window, you can select the TV channel or video input by pressing **OPTIONS** and select “Sub window”.

To return to single picture mode

Press **⊕**, **□**, **RETURN** or select “Single Picture” from Options menu.

- You cannot use the component video jack **④** and the video jack **⑤** 1 at the same time.
- You cannot change the size of the pictures.
- In Twin Picture mode, as picture size reduced, this may decrease picture smoothness.
- The highlighted picture is audible. You can switch the audible picture by pressing **↔**.
- You can also use the Twin Picture feature by selecting “Twin Picture” from the Options menu.

Viewing PIP (Picture in Picture)

You can view two pictures (in PC input mode) on the screen simultaneously.

Connect a PC (page 15), and make sure that images from a PC appear on the screen (page 16).

1 Press **□**.

Two pictures are displayed simultaneously.



PIP Availability

In Main Window	In Sub Window
PC HDMI 1/2* (PC timing)	TV programme or Video 1/2

* Not available for KLV-32BX311

2 In sub window, you can select the TV channel or video input by pressing **OPTIONS** and select “Sub window”.

To return to single picture mode

Press **□**, **RETURN** or select “Single Picture” from Options menu.

- You cannot display resolutions higher than your TV's display resolution (page 39).
- In PIP mode, as picture size reduced, this may decrease picture smoothness.
- You can switch the audible picture by selecting “Audio Swap” from the Options menu.
- You can also use the PIP feature by selecting “PIP” from the Options menu.

Using Menu Functions

Navigating through menus

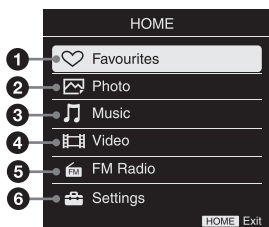

The **HOME** button allows you to access a variety of TV settings, USB media files and FM Radio mode.

- 1 Press **HOME** on the TV or remote.
- 2 Press \uparrow/\downarrow to select an option, then press \oplus .
- 3 Follow the instructions on the screen.
- 4 To exit the menu, press **HOME**.

Menu	Description
1 Favourites	You can store up to 10 channels and/or external inputs in your Favourite list.
2 Photo	You can enjoy photo files via USB devices (page 19).
3 Music	You can enjoy music files via USB devices (page 19).
4 Video	You can enjoy video files via USB devices (page 19).
5 FM Radio	Listens to the FM Radio (page 22).
6 Settings	Displays the “Settings” menu where most of the advanced settings and adjustments are performed. For details about settings, see page 24 to 33.

Using the Favourites

Allows you to set your favourite channels and/or external input by assigning the desired channel numbers and/or external input.

To watch a channel or external input

Press \uparrow/\downarrow to select the channel number or external input, then press \oplus .

To turn off the Favourite list

Press **RETURN** to return to the previous screen.

Add a current channel or external input to the Favourite list

Press \uparrow/\downarrow to select “Add to Favourites”, then press \oplus .

- Favourite channels and external inputs can also be added using the **OPTIONS** button on the remote.
- Your Favourites list will be cleared each time you run the “Auto Tuning”.
- When you continue to add items beyond the 10th item, the bottom item in the list will be automatically removed from the Favourite list.

Playing back photo/music/video via USB

You can enjoy photo/music/video files stored in a Sony digital still camera or camcorder through a USB cable or USB storage device on your TV.

- 1 Connect a supported USB device to the TV.
 - 2 Press **HOME**.
 - 3 Press \swarrow/\searrow to select “Photo”, “Music” or “Video”.
 - 4 The thumbnail view of file or folder appears.
If more than one USB device is detected, press the red button to select “Device Selection” from the list of available options and press \oplus , then press $\swarrow/\searrow/\swarrow/\searrow$ to select a USB device and press \oplus .
 - 5 Press $\swarrow/\searrow/\swarrow/\searrow$ to select a file or folder, then press \oplus .
When you select a folder, select a file, then press \oplus .
Playback starts.
-  • If you connect the USB device when “USB Auto Start” is set to “On” (page 31), the thumbnail view of the last played Photo/Music/Video appears automatically.

Basic operation of Photo/Music/Video

You can operate the connected USB device by the TV remote.

Item	Description
\lll / \ggg	Fast reverses/fast forwards the file when pressed during playback.
\lll / \ggg	Goes to the beginning of the previous/ next file.
\blacktriangleright	Starts playback.
\parallel	Pauses playback.
\blacksquare	Stops playback.

-  • If a video file has subtitles, they can be displayed by pressing the green button during DivX playback.

To use playback options

Press the coloured buttons to display a list that contains shortcuts to some setting menus. The listed options vary depending on the current input and content.

Photo

“**Slideshow Effect**”: Selects an effect for a slideshow.

“**Slideshow Speed**”: Selects the slideshow duration.

“**Shuffle**”: Plays a file in random order.

“**Zoom**”: Magnifies the picture (“1x”, “2x” or “4x”)

Music

“**Playback Target**”: Selects to play all files, or one selected file.

“**Shuffle**”: Plays files in random order.

“**Speakers**”: Selects a speaker (page 26).

Video

“**Playback Target**”: Selects to play all files, or one selected file.

“**Zoom**”*: Magnifies the picture (“1x”, “2x”, “4x” or “Full”)

“**Speakers**”: Selects a speaker (page 26).

* When you set “Zoom”, stop video playback.

General

“**Repeat**”: Plays a file repeatedly.

“**File Order**”: Changes file order

“**Device Selection**”: Selects a USB device.

To set the picture (Video)

You can adjust the picture quality of USB Video.

- 1 Select a video.
See “Playing back photo/music/video via USB” (page 19).
- 2 Press **OPTIONS** during playback, then press \swarrow/\searrow to select “Picture” and press \oplus .
- 3 Press $\swarrow/\searrow/\swarrow/\searrow$ to select the item, then press \oplus .
- 4 Press $\swarrow/\searrow/\swarrow/\searrow$ to adjust the setting, then press \oplus .

To play a photo as a slideshow (Photo)

You can play a slideshow with photos. “Slideshow Effect” and “Slideshow Speed” can be set.

- 1 Select a photo.
See “Playing back photo/music/video via USB” (page 19).
- 2 Press the green button in thumbnail view, or press **OPTIONS** while a photo is displayed, then press \swarrow/\searrow to select “Slideshow” and press \oplus .

To stop a slideshow

Select “Stop Slideshow” from Options menu.

- While the TV is accessing the data on the USB device, observe the following:
 - Do not turn off the TV or connected USB device.
 - Do not disconnect the USB cable.
 - Do not remove the USB device.The data on the USB device may be damaged.
- Sony will not be held liable for any damage to, or loss of, data on the recording media due to a malfunction of any connected devices or the TV.
- The file name and folder name may not display correctly in some cases.
- When you connect a Sony digital still camera, set the camera’s USB connection mode to Auto or Mass Storage. For more information about USB connection mode, refer to the instructions supplied with your digital camera.
- Check the website below for updated information about compatible USB devices.
<http://www.sony-asia.com/bravia/flash.html>
- Use a USB storage device that is compliant with USB mass storage device class standards.
- If a selected file has incorrect container information, or is incomplete, it cannot be played back.
- BRAVIA TV supports DivX®.

USB Video format

Extension	Container	Video Codec	Audio Codec
.avi	AVI	DivX 3.11/4.x/5.1	PCM / MPEG1 Layer1, 2 / MP3 / MPEG2 AAC (2ch) / MPEG4 AAC (2ch) / MPEG4 HE-AAC (2ch) / Dolby Digital (2ch) / WMA v8
		XviD	
		MPEG1	
		MPEG2 MP	
		H.264 BP/MP/HP	
		MPEG-4 SP/ASP	
.wmv .asf	ASF	WMV v9	MP3 / WMA v8
		Divx 3.11	
		XviD	
		MPEG-4 SP/ASP	
		VC-1	
.mp4 .mov .3gp	MP4	H.264 BP/MP/HP	MPEG1 Layer1, 2 / MP3 / MPEG2 AAC / MPEG4 AAC / MPEG4 HE-AAC
		MPEG-4 SP/ASP	
		H.263	
.mkv	MKV	H.264 BP/MP/HP	PCM / MPEG1 Layer1, 2 / MP3 / MPEG2 AAC (2ch) / MPEG4 AAC (2ch) / MPEG4 HE-AAC (2ch) / Dolby Digital (2ch) / WMA v8
		MPEG-4 SP/ASP	
		WMV v9	
		DivX 3.11/4.x/5.1	
		VC-1	
.mpg .mpeg .vob	PS	MPEG1	MPEG1 Layer1, 2 / MP3 / Dolby Digital (2ch)
		MPEG2 MP	
.ts, .m2ts	TS	MPEG2 MP	MPEG1 Layer1, 2 / MP3 / MPEG2 AAC / MPEG4 AAC / MPEG4 HE-AAC
		VC-1	
		H.264 BP/MP/HP	

USB Music format

Extension	Audio Codec
.mp3	MP3
.wma	WMA v8

USB Photo format

Extension	Image Codec
.jpg, .jpeg	JPEG

DCF2.0 or EXIF2.21 supported.

 • Playback of the above file formats is not guaranteed.

Listening to the FM Radio

You are able to listen to the FM radio stations using your TV by connecting an antenna (page 7). FM Radio tuning range is from 87.5-108.0 MHz.

When you use the FM Radio function for the first time, press **HOME** and select “FM Radio”, then perform “Auto Tuning” in the “FM Radio Set-up” menu (page 30).

To	Do this
Access to FM Radio mode	Press HOME and select “FM Radio”.
Exit from FM Radio mode	Press RETURN to return to previous view input.
Listen to preset stations	<ol style="list-style-type: none"> 1 Access to FM Radio mode. 2 Press HOME and select “Settings”. Preset the desired FM radio stations and its labels in “FM Radio Set-up” from “Channel Set-up” menu (page 29). <ul style="list-style-type: none"> • You can also access to “FM Radio Presets” by selecting “FM Radio Presets” from the Options menu in FM Radio mode. 3 Exit from “Channel Set-up” menu by pressing HOME. The selected preset FM radio station number and label will appear on the screen. To select the desired preset FM radio station, press PROG +/-. <ul style="list-style-type: none"> • You can also use the 0-9 buttons on the remote to directly select the desired preset FM radio station.
Listen to non-preset stations	<ol style="list-style-type: none"> 1 Access to FM Radio mode. 2 Press \leftarrow/\rightarrow to manually search for the desired FM radio station. It will search and stop when found the next available station. <ul style="list-style-type: none"> • You can also tune FM frequency for the desired FM radio station by pressing \leftarrow/\rightarrow. The available radio frequency is only for temporary listening pleasure and cannot be stored in the memory. • If the message “Please set-up FM Radio.” appears, display the “Channel Set-up” menu and select “FM Radio Set-up” to preset the desired FM radio stations (page 30).
Show Slideshow while listening to FM Radio	<ol style="list-style-type: none"> 1 You must access “Slideshow” from the “Photo” menu to view your personal pictures. 2 Press RETURN twice to exit “Slideshow”. 3 Access to FM Radio mode. 4 Press OPTIONS to select “Slideshow”, then press \oplus. 5 Press $\text{⏏}/?$ to end “Slideshow”. <ul style="list-style-type: none"> • BRAVIA images will be displayed if a USB device is not connected or step 1 and 2 are not performed.
Show picture frame while listening to FM Radio	<ol style="list-style-type: none"> 1 You must access “Picture Frame Image” from the “Photo” menu to view your personal picture. 2 Press RETURN twice to exit “Picture Frame Image”. 3 Access to FM Radio mode. 4 Press OPTIONS to select “Picture Frame Image”, then press \oplus. 5 Press $\text{⏏}/?$ to end “Picture Frame Image”. <ul style="list-style-type: none"> • BRAVIA image will be displayed if a USB device is not connected or step 1 and 2 are not performed.
Reduce power consumption while in FM Radio mode	<ol style="list-style-type: none"> 1 Press OPTIONS to select “Power Saving”. Select the desired options and press \oplus. <ul style="list-style-type: none"> • You can also access to “Power Saving” by selecting “Eco” from the setting menu (page 33). 2 Exit from “Picture Off” by pressing any key on the remote except \leftarrow +/-, ⏏ or AUDIO.

- If the station has a noisy sound, you may be able to improve the sound quality by pressing \leftarrow/\rightarrow .
- When a FM stereo programme has static noise, press **AUDIO** until “Mono” appears. There will be no stereo effect, but the noise will be reduced.
- If CATV is connected, FM Radio may not be able to be received.

Using BRAVIA Sync with Control for HDMI

The Control for HDMI function enables the TV to communicate with the connected equipment that is compatible with the function, using HDMI CEC (Consumer Electronics Control). For example, by connecting Sony equipment that is compatible with Control for HDMI (with HDMI cables), you can control them together.

Be sure to connect the equipment correctly, and make the necessary settings.

Control for HDMI

- Automatically turns the connected equipment off when you switch the TV to standby mode using the remote.
- Automatically turns the TV on and switches the input to the connected equipment when the equipment starts to play.
- If you turn on a connected audio system while the TV is on, the sound output switches from the TV speaker to the audio system.
- Adjusts the volume (◀ +/-) and mutes the sound (⊗) of a connected audio system.
- You can operate the connected Sony equipment that has the BRAVIA Sync logo by the TV remote. Possible operations with BRAVIA Sync buttons, see page 12.
 - Refer to the instruction manual of the equipment for available control.
- If “Control for HDMI” of the TV is set to “On”, “Control for HDMI” of the connected equipment is also automatically switched to “On”.



To make the Control for HDMI settings

The Control for HDMI settings must be set on both the TV side and connected equipment side. See “HDMI Set-up” (page 32) for the TV side settings. For settings on the connected equipment, refer to its operating instructions.

Settings adjustment

 • The options you can adjust vary depending on the situation. Unavailable options are greyed out or not displayed.

Picture

Picture Mode	Sets a picture mode. The options that can be selected differ depending on the “Scene Select” settings. “ Vivid ”: Enhances picture contrast and sharpness. “ Standard ”: For standard pictures. Recommended for home entertainment. “ Custom ”: Allows you to store your preferred settings. “ Cinema ”: For film-based content. Suitable in a theatre-like environment. “ Photo ”: For standard viewing of photographs. “ Sports ”: Optimizes picture quality for viewing sports. “ Game ”: Select for standard picture suitable for games. “ Graphics ”: Optimizes picture quality for viewing graphics.
Reset	Resets all the “Picture” settings except “Picture Mode” and “Intelligent Picture Plus Set-up” to the factory settings.
Backlight	Adjusts the brightness of the backlight.
Picture	Increases or decreases picture contrast.
Brightness	Brightens or darkens the picture.
Colour	Increases or decreases colour intensity.
Hue	Increases or decreases the green tones and red tones.  • When viewing TV programme or video input, “Hue” is only available for NTSC colour system.
Sharpness	Sharpens or softens the picture.
Colour Temperature	Adjusts the whiteness of the picture. “ Cool ”: Gives the white colours a blue tint. “ Neutral ”: Gives the white colours a neutral tint. “ Warm ”: Gives the white colours a red tint.  • “Warm” is not available when “Picture Mode” is set to “Vivid”.
Noise Reduction	Reduces the picture noise (snowy picture) in a weak broadcast signal.
MPEG Noise Reduction	Reduces the picture noise in MPEG-compressed video.
Cinema Drive	Provides improved picture movement when playing BD (Blu-ray Disc), DVD or VCR images taken on film, reducing picture blur and graininess. Select “Auto” to represent original film-based content as is.  • If the image contains irregular signals or too much noise, “Cinema Drive” is automatically turned off even if “Auto” is selected.

Advanced Settings	<p>Allows you to set “Picture” settings in more detail. These settings are not available when “Picture Mode” is set to “Vivid”.</p> <p>“Reset”: Resets all the advanced settings to the factory settings.</p> <p>“Adv. Contrast Enhancer”: Automatically adjusts “Backlight” and “Picture” to the most suitable settings judging from the brightness of the screen. This setting is especially effective for dark images scenes, and will increase the contrast distinction of the darker picture scenes.</p> <p>“Black Corrector”: Enhances black areas of the picture for stronger contrast.</p> <p>“Gamma”: Adjusts the balance between bright and dark areas of the picture.</p> <p>“Clear White”: Emphasises white colours.</p> <p>“Live Colour”: Makes colours more vivid.</p>
--------------------------	--





Intelligent Picture Plus Set-up	<p>“Intelligent Picture Plus”</p> <p>Allows you to improve the picture when viewing TV programme or video input. The options that can be selected differ depending on the “Scene Select” settings.</p> <p>“Signal Level Indicator”</p> <p>Turns on/off the “Signal Level Indicator” feature. When “On” is selected, the signal level bar will be displayed when you select a channel or video input.</p> <p>“Picture Optimisation”</p> <p>Allows you to enhance the picture to your preferred settings.</p> <p>“Crisp”: For a sharper image with more visible noise.</p> <p>“Smooth”: For a softer image with less visible noise.</p>
--	--

Sound

Sound Mode	<p>Sets a sound mode. The options that can be selected differ depending on the “Scene Select” settings.</p> <p>“Dynamic”: Enhances treble and bass. Recommended for home entertainment.</p> <p>“Standard”: For standard sound.</p> <p>“Clear Voice”: Makes voice sound clearer.</p>
Reset	<p>Resets all the “Sound” settings except “Sound Mode”, “Dual Sound”, “Speakers”, “Audio Out”, “Headphone Speaker Link”, “Headphone Volume” and “HDMI/DVI Audio Source” to the factory settings.</p>
7 Band Equalizer	<p>Adjusts sound frequency settings.</p> <p>Press \leftarrow/\rightarrow to select the desired sound frequency, then press \uparrow/\downarrow to adjust the setting and press \oplus. The adjusted settings will be received when you select “Sound Mode” options. Selecting “Reset” will set the “7 Band Equalizer” to original settings.</p> <p>\leftarrow/\rightarrow • Adjusting higher frequency will affect higher pitched sound and adjusting lower frequency will affect lower pitched sound.</p>
Balance	<p>Emphasises left or right speaker balance.</p>
Intelligent Volume	<p>Minimizes the difference in volume level between all programmes and adverts (e.g. adverts tend to be louder than programmes).</p>
Volume Offset	<p>Adjusts the volume level of the current input relative to other inputs.</p>

Surround	<p>Allows you to select the suitable surround effects depending on the genre of TV programme (movie, sport, music, etc.) or video game.</p> <p>The options that can be selected differ depending on the “Scene Select” settings.</p> <p>“On”: Delivers surround effects that help you enjoy the virtual two-ch surround audio with just the two internal TV speakers.</p> <p>“Simulated Stereo”: Adds a surround-like effect to mono programmes.</p> <p>“Cinema”: Delivers surround effects just like the high-grade audio systems found in movie theatres.</p> <p>“Music”: Delivers surround effects that make you feel like you are surrounded by sound as in a music hall.</p> <p>“Sports”: Delivers surround effects that make you feel like you are watching a live sports contest.</p> <p>“Game”: Delivers surround effects that enhance game sound.</p> <p>“Off”: Converts and reproduces multi-ch audio to 2ch audio. In the case of other audio formats, the original audio is reproduced.</p>
Bass Booster	Produces a fuller sound for more impact, by emphasising the bass sounds.
Dual Sound	<p>Sets the sound from the speaker for a stereo or bilingual broadcast.</p> <p>“Stereo”/“Mono”: For stereo broadcasts.</p> <p>“Main”/“Sub”/“Mono”: For bilingual broadcasts, select “Main” for sound channel 1, “Sub” for sound channel 2, or “Mono” for mono channel, if available.</p> <ul style="list-style-type: none"> • If the signal is very weak, the sound becomes monaural automatically. • If the stereo sound is noisy when receiving a NICAM programme, select “Mono”. The sound becomes monaural, but the noise is reduced. • The “Dual Sound” setting is memorized for each programme position. • You cannot listen to stereo broadcast sound when “Mono” is selected. <ul style="list-style-type: none"> • If you select other equipment connected to the TV, set “Dual Sound” to “Stereo”, “Main” or “Sub”. However, when the external equipment connected to the HDMI jack (except HDMI 1) is selected, this is fixed to “Stereo”. • If you access to FM Radio mode, set “Dual Sound” to “Stereo” or “Mono”.
Speakers	<p>“TV Speakers”: Turns on and outputs the TV’s sound from the TV speakers.</p> <p>“Audio System”: Turns off the TV speakers and outputs the TV’s sound from external audio equipment connected to the audio output jacks on the TV.</p> <p>You can also turn on the connected equipment that is compatible with Control for HDMI, after making the appropriate settings of Control for HDMI.</p>
Audio Out	<p>“Variable”: When using an external audio system, volume output from audio out can be controlled using the TV’s remote.</p> <p>“Fixed”: The audio output of the TV is fixed. Use your audio receiver’s volume control to adjust the volume (and other audio settings) through your audio system.</p>
Headphone Speaker Link	Switches the TV’s internal speakers on/off when you connect headphones to the TV.
Headphone Volume	Adjusts the volume of the headphones.
HDMI/DVI Audio Source	Switches the audio signal for HDMI input when a DVI device is connected. Select from “Auto”, “HDMI Audio” and “PC Audio”.

Screen

Wide Mode	For details about wide mode, see page 13.
Auto Wide	Automatically changes the wide mode according to the input signal from an external equipment. To keep your setting, select “Off”.  • “Auto Wide” is only available when watching programmes from video input, HDMI and component input in format 480i or 576i.  • Even if “Auto Wide” is set to “On” or “Off”, you can always modify the format of the screen by pressing  repeatedly.
4:3 Default	Selects the default screen mode for use with 4:3 broadcasts. “ Wide Zoom ”: Enlarges the 4:3 picture to fill the 16:9 screen, keeping the original image as much as possible. “ Normal ”: Displays conventional 4:3 broadcasts in the correct proportions. “ Off ”: Keeps the current “Wide Mode” setting when the channel or input is changed.
Auto Display Area	“ On ”: Automatically adjusts the display area based upon the content. “ Off ”: Turns off the “Auto Display Area”. Choose one from the “Display Area” options.
Display Area	Adjusts the picture display area. “ Full Pixel ”: Displays the picture for 1080/50i, 1080/60i, 1080/50p and 1080/60p sources (HDMI or component input only) or 1080/24p sources (HDMI input only) in the original size. (Available depending on the TV model.) “ +1 ”: Displays pictures in their original size. “ Normal ”: Displays pictures in their recommended size. “ -1 ”: Enlarges the picture so that the edges are outside the visible display area.
Horizontal Shift	Adjusts the horizontal position of the picture when “Wide Mode” is set to “Wide Zoom” or “Zoom”.
Vertical Shift	Adjusts the vertical position of the picture when “Wide Mode” is set to “Wide Zoom” or “Zoom”.
PC Settings	“ Wide Mode ” Selects a screen mode for displaying input from your PC, see page 13. “ Reset ” Resets all the “PC Settings” except “Wide Mode” to the factory settings. “ Auto Adjustment ” Automatically adjusts the display position, phase and pitch of the picture when the TV receives an input signal from the connected PC.  • “Auto Adjustment” may not work well with certain input signals. In such cases, manually adjust “Phase”, “Pitch”, “Horizontal Shift” and “Vertical Shift”. “ Phase ” Adjusts the phase when the screen flickers. “ Pitch ” Adjusts the pitch when the picture has unwanted vertical stripes. “ Horizontal Shift ” Adjusts the horizontal position of the picture. “ Vertical Shift ” Adjusts the vertical position of the picture.

PC input signal reference chart for PC and HDMI IN

For KLV-40NX520/KLV-40CX420/KLV-40BX420/KLV-32NX520/KLV-32CX420





























Signals	Horizontal (Pixel)	Vertical (Line)	Horizontal frequency (kHz)	Vertical frequency (Hz)	Standard
VGA	640	480	31.5	60	VGA
SVGA	800	600	37.9	60	VESA Guidelines
XGA	1024	768	48.4	60	VESA Guidelines
WXGA	1280	768	47.4	60	VESA
WXGA	1280	768	47.8	60	VESA
WXGA	1360	768	47.7	60	VESA
SXGA	1280	1024	64	60	VESA
HDTV	1920	1080	67.5	60	EIA

For KLV-32CX320/KLV-32BX320/KLV-32BX311/KLV-26CX320/KLV-26BX320/KLV-22CX320/
KLV-22BX320

Signals	Horizontal (Pixel)	Vertical (Line)	Horizontal frequency (kHz)	Vertical frequency (Hz)	Standard
VGA	640	480	31.5	60	VGA
SVGA	800	600	37.9	60	VESA Guidelines
XGA	1024	768	48.4	60	VESA Guidelines
WXGA	1280	768	47.4	60	VESA
WXGA	1280	768	47.8	60	VESA
WXGA	1360	768	47.7	60	VESA

-  This TV's PC input does not support Sync on Green or Composite Sync.
- This TV's PC input does not support interlaced signals.
- This TV's PC input supports signals in the above chart with a 60 Hz vertical frequency.

Channel Set-up

1 Digit Direct	<p>When “1 Digit Direct” is set to “On”, you can select a channel using one preset number button (0 - 9) on the remote.</p> <p> • When “1 Digit Direct” is set to “On”, you cannot select channel numbers 10 and above entering next digit using the remote.</p>
Auto Tuning	<p>Tunes in all the available channels. This option allows you to retune the TV after moving house, or to search for new channels that have been launched by broadcasters.</p>
Programme Sorting	<p>Changes the order in which the channels are stored on the TV.</p> <ol style="list-style-type: none">1 Press  to select the channel you want to move to a new position, then press .2 Press  to select the new position for your channel, then press .
Programme Labels	<p>Assigns a channel name of your choice up to seven letters or numbers.</p> <ol style="list-style-type: none">1 Press  to select the channel you want to name, then press .2 Press  to select the desired letter or number (“_” for a blank space), then press . <p>If you input a wrong character</p> <p>Press  to select the wrong character. Then, press  to select the correct character.</p> <p>To delete all the characters</p> <p>Select “Reset”, then press .</p> <ol style="list-style-type: none">3 Repeat the procedure in step 2 until the name is completed, then press .
Manual Programme Preset	<p>Before selecting “Label”/“AFT”/“Audio Filter”/“Skip”/“Colour System”, press PROG +/- to select the programme number with the channel. You cannot select a programme number that is set to “Skip” (page 30).</p> <p>“Programme”/“TV System”/“Frequency”</p> <p>Presets programme channels manually.</p> <ol style="list-style-type: none">1 Select “Programme”, then press .2 Press  to select the programme number you want to manually tune (if tuning a VCR, select channel 0), then press RETURN.3 Press  to select “TV System”, then press .4 Press  to select your TV broadcast systems, then press .5 Press  to go to the frequency range indication (“VHF Low”, “VHF High” or “UHF”), then press .6 Tune the channels as follows: Press  to search for the next available channel. When a channel has been found, the search will stop. To continue searching, press . <p>Repeat the procedure above to preset other channels manually.</p> <p>“Label”</p> <p>Assigns a name of your choice, up to seven letters or numbers, to the selected channel. To input characters:</p> <ol style="list-style-type: none">1 Press  to select the desired letter or number (“_” for a blank space), then press . <p>If you input a wrong character</p> <p>Press  to select the wrong character. Then, press  to select the correct character.</p> <ol style="list-style-type: none">2 Repeat the procedure in step 1 until the name is completed, then press . <p>“AFT”</p> <p>Allows you to fine-tune the selected channel manually. When “On” is selected, the fine tuning is performed automatically.</p>

“Audio Filter”

Improves the sound of individual channels when distortion occurs in mono broadcasts in TV system “B/G”, “I” and “D/K”.

 • You cannot receive stereo or dual sound when “High” is selected.

“Skip”

Skips unused channels when you press **PROG +/-** to select channels. (You can still select a skipped channel using the number buttons.)

“Colour System”

Selects the colour system (“Auto”, “PAL”, “SECAM”, “NTSC3.58”, “NTSC4.43” or “PAL60”) according to the channel.

“Signal Level”

Displays the signal level for programme currently being watched.

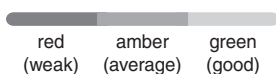

FM Radio Set-up

Preset up to 30 FM radio stations that can be received in your area.

“Auto Tuning”

Allows you to automatically tune and store all the available channels.

1 Select “Auto Tuning”, then press \oplus .

2 Select “OK” to automatically tune in all the available channels.

“FM Radio Presets”

Manually tune and store each available channel one at a time.

1 Press \uparrow/\downarrow to select the desired FM radio station position, then press \oplus .

2 Press \uparrow/\downarrow to search the FM radio stations. Searching stops automatically when a station is tuned in. If the station has a noisy sound, you may be able to improve the sound quality by pressing \leftarrow/\rightarrow . Press \oplus to store the FM radio station.

You may edit the FM radio station label. Press \uparrow/\downarrow to select alphanumeric characters for the label, then press \oplus . Repeat steps 1 to 2 to preset other FM radio stations.

 • To enable this feature, access to FM Radio mode by using HOME (Menu) (page 18), then preset your desired FM radio stations according to the steps mentioned above.

Parental Lock

PIN Code Allows you to set up TV to block channel or external input. Use 0-9 on the remote to enter a four-digit PIN code.

Change PIN Code Selects to change your PIN code.



















Programme Block Blocks an individual channel from being watched.
To view a blocked channel, select “Unblocked”.

External Input Lock Locks an external input from being watched.
To view a blocked external input, select “Unblocked”.

 • Entering the correct PIN code for blocked channel or external input will temporarily deactivates the “Parental Lock” feature. To reactivate the “Parental Lock” settings, turn off and on the TV.

 • If you lost your PIN code, see page 38.

Set-up

USB Auto Start	Automatically enters the thumbnail view of the last played Photo/Music/Video when the TV is turned on and a USB device is connected to the USB port then turned on.
Sleep Timer	Set the time in minutes (“Off”, “15”, “30”, “45”, “60”, “90”, or “120”) that you would like the TV to remain on before shutting off automatically.
Auto Start-up	Starts the initial set-up procedure (page 8). This option allows you to retune the TV after moving house, or to search for new channels that have been launched by broadcasters.
Language	Selects the language in which the menus are displayed.
Start-up Sound	Select “On” to play sound when the TV is turned on. Select “Off” to disable it.
AV Set-up	<p>“Video Labels”</p> <p>Assigns a name to any equipment connected to the side and rear jacks. The name will be displayed briefly on the screen when the equipment is selected.</p> <p>1 Press / to select the desired input source, then press .</p> <p>2 Press / to select the desired option below, then press .</p> <p>Equipment labels: Uses one of the preset labels to assign a name to connected equipment.</p> <p>“Edit”: Creates your own label. Follow steps 2 to 3 of “Programme Labels” (page 29).</p> <p>“Skip”: Skips an unnecessary input source.</p> <p>“Colour System”</p> <p>Selects the colour system (“Auto”, “PAL”, “SECAM”, “NTSC3.58”, “NTSC4.43” or “PAL60”) according to the composite video signal from the input source.</p> <p>“Video 2 Input/Output”</p> <p>Switches the video jack  2 between input and output modes.</p> <p>When set to “Output”, outputs whatever is being viewed on the screen (except signals from the /, HDMI IN and / PC IN jacks).</p> <p>“Video 1/Component Input”</p> <p>Select “Auto” to have the TV detect and switch between the component video jack  or the video jack  1 when component video jack  or video jack  1 is connected.</p> <p> • You cannot use the component video jack  and the video jack  1 at the same time.</p>

HDMI Set-up

Allows the TV to communicate with equipment that is compatible with the Control for HDMI function, and connected to the HDMI jacks of the TV. Note that communication settings must also be made on the connected equipment.

“Control for HDMI”

Sets whether or not to link the operations of the TV and the connected equipment that is compatible with Control for HDMI. When set to “On”, the following functions are available.

If the specific Sony equipment that is compatible with Control for HDMI is connected, this setting is applied to the connected equipment automatically when the “Control for HDMI” is set to “On” using the TV.

“Auto Devices Off”

When this is set to “On”, the connected equipment that is compatible with Control for HDMI turns off when you turn off the TV by remote.

“Auto TV On”

When this is set to “On”, the TV turns on when you turn on the connected equipment that is compatible with Control for HDMI.

“HDMI Device List”

Displays a list of connected equipment that is compatible with Control for HDMI.

Selects “Enable” to update the “HDMI Device List”.

“Device Control Keys”

Select button functions of the TV’s remote control to operate the connected equipment.

“Normal”: For basic operations, such as navigation buttons (up, down, left or right, etc).

“Tuning Keys”: For basic operations and operation of channel-related buttons, such as **PROG +/-** or **(0-9)**, etc. Useful when you control a tuner or set-top box, etc; via the remote control.

“Menu Keys”: For basic operations and operation of the **HOME/OPTIONS** buttons. Useful when you select menus of a BD player, etc; via the remote control.

“Tuning and Menu Keys”: For basic operations and operation of channel-related buttons and **HOME/OPTIONS** button.

- You cannot use “Control for HDMI” if the TV operations are linked to the operations of an audio system that is compatible with Control for HDMI.
- Some equipment with “Control for HDMI” does not support the “Device Control” feature.

DivX(R) VOD

Select “DivX(R) VOD Registration Code” to register your TV for playback of DivX contents. Select “DivX(R) VOD Deregistration Code” to delete the registration.

- A new registration code will be displayed in “DivX(R) VOD Registration Code” after deleting registration via “DivX(R) VOD Deregistration Code”.

Product Information

Displays your TV’s product information.

Factory Settings

Resets all settings to factory settings. After completing this process, the initial set-up screen is displayed.

- Be sure not to turn the TV off during this period (it takes about 30 seconds) or press any buttons.
-

 **Eco**

Reset	Resets the current Eco settings to the default values.
Power Saving	Reduces power consumption of the TV by adjusting the backlight. When you select “Picture Off”, the picture is switched off, and the  (Picture Off) indicator on the TV front panel lights up in green. The sound remains unchanged.
Idle TV Standby	Turns the TV off after it has been kept idle for the preset length of time.
Light Sensor	Optimises the picture settings according to the ambient lighting. (KLV-40/32/26/ 22CX420/320 only)
PC Power Management	Switches the TV to standby mode when the TV receives no signal from the PC input source for 30 seconds.

Installing the accessories (Wall-Mount Bracket)

To Customers:

For product protection and safety reasons, Sony strongly recommends that installing of your TV be performed by Sony dealers or licensed contractors. Do not attempt to install it yourself.

To Sony Dealers and Contractors:

Provide full attention to safety during the installation, periodic maintenance and examination of this product.

Your TV can be installed using the Wall-Mount Bracket SU-WL50B or SU-WL100 (sold separately).

- Refer to the Instructions supplied with the Wall-Mount Bracket to properly carry out the installation.
- Refer to “Detaching the stand from the TV” (page 9).

 • Place the TV on the stand, when securing the Mounting Hook.

SU-WL100: (KLV-26/22CX320/KLV-26/22BX320)

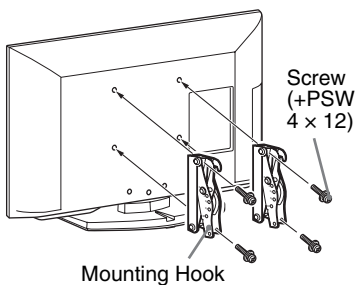

SU-WL50B: (KLV-40/32NX520/KLV-40/32CX420/KLV-40BX420/ KLV-32CX320/KLV-32BX320/KLV-32BX311)

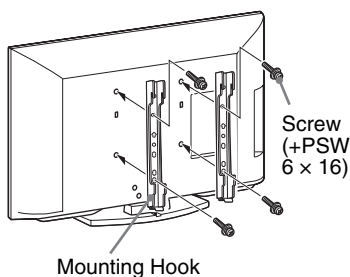

Note when installing

When using the SU-WL50B or SU-WL100 Wall-Mount Bracket, the space between the wall and the TV will be 6 cm. Use this space to route cables to the TV.

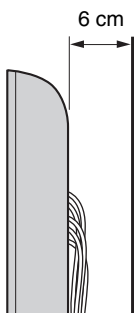

Sufficient expertise is required for installing these products, especially to determine the strength of the wall for withstanding the TV's weight. Be sure to entrust the attachment of these products to the wall to Sony dealers or licensed contractors and pay adequate attention to safety during the installation. Sony is not liable for any damage or injury caused by mishandling or improper installation.

TV installation dimensions table

SU-WL100:

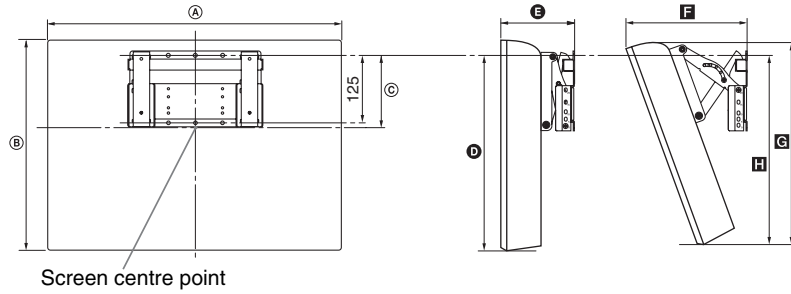

Unit: mm

Model name	Display dimensions		Screen centre dimension	Length for each mounting angle				
	A	B		Angle (0°)		Angle (20°)		
			D	E	F	G	H	
KLV-26CX320	672	423	125	335	160	255	401	340
KLV-26BX320	668	424	117	336	147	244	403	338
KLV-22CX320	551	367	133	329	143	222	348	329
KLV-22BX320	551	363	107	302	122	212	338	295

SU-WL50B:

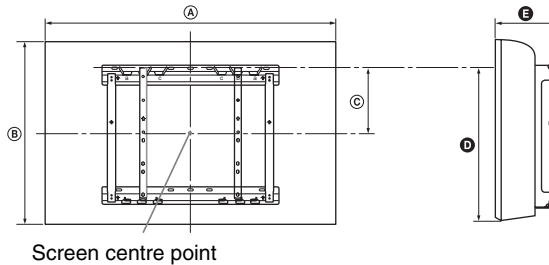

Unit: mm

Model name	Display dimensions		Screen centre dimension	Length for mounting	
	A	B		D	E
KLV-40NX520	1,000	609	175	481	147
KLV-40CX420	992	598	175	478	161
KLV-40BX420	988	600	175	478	147
KLV-32NX520	812	502	200	453	148
KLV-32CX420/ KLV-32CX320	800	497	200	454	158
KLV-32BX320/ KLV-32BX311	800	496	200	453	147

Figures in the above table may differ slightly depending on the installation.

WARNING

The wall that the TV will be installed on should be capable of supporting a weight of at least four times that of the TV. Refer to “Specifications” for its weight.

Screw and hook locations diagram/table

Screw location - When installing the Mounting Hook on the TV.

SU-WL50B

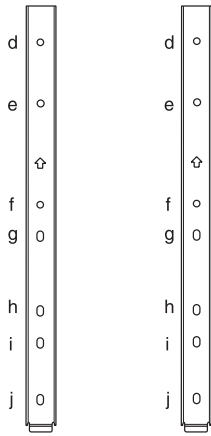

Hook location - When installing the TV onto the Base Bracket.

SU-WL100

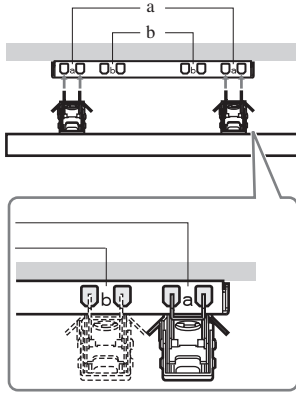

SU-WL50B

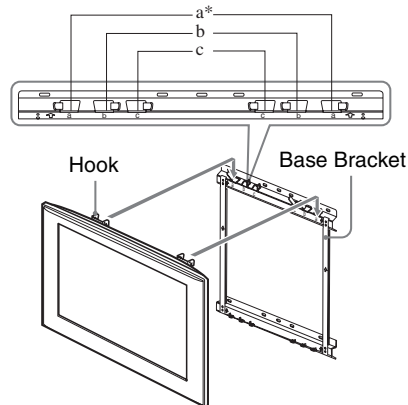

* Hook location "a" cannot be used for the models in the table below.

Model name	Screw location	Hook location
	SU-WL50B	SU-WL50B
KLV-40NX520/KLV-40CX420/KLV-40BX420	d, i	b
KLV-32NX520/KLV-32CX420/KLV-32CX320/ KLV-32BX320/KLV-32BX311	e, h	c
		SU-WL100
		a
		b

Troubleshooting

Check whether the  (standby) indicator is flashing in red.

When it is flashing

The self-diagnosis function is activated.

- 1 Count how many times the  (standby) indicator flashes between each three second break.

For example, the indicator flashes three times, then there is a three second break, followed by another three flashes, etc.



- 2 Press  on the TV to turn it off, disconnect the AC power cord, and inform your dealer or Sony service centre of how the indicator flashes (number of flashes).

When it is not flashing

- 1 Check the items listed below.
- 2 If the problem still persists, have your TV serviced by qualified service personnel.

Picture

No picture (screen is dark) and no sound

- Check the antenna/cable connection.
- Connect the TV to the AC power outlet, and press  on the TV.
- If the  (standby) indicator lights up in red, press .

No picture or no menu information from equipment connected to the video input jack appears on the screen

- Press  to display the connected equipment list, then select the desired input.
- Check the connection between the optional equipment and the TV.

Double images or ghosting

- Check the antenna/cable connection, location or direction.

Only snow and noise appear on the screen

- Check if the antenna is broken or bent.
- Check if the antenna has reached the end of its serviceable life (three to five years in normal use, one to two years at the seaside).

Distorted picture (dotted lines or stripes)

- Keep the TV away from electrical noise sources such as cars, motorcycles, hair-dryers or optional equipment.
- When installing optional equipment, leave some space between the optional equipment and the TV.
- Check the antenna/cable connection.
- Keep the antenna cable away from other connecting cables.

Picture or sound noise when viewing a TV channel

- Adjust “AFT” (Automatic Fine Tuning) to obtain better picture reception (page 29).

Some tiny black points and/or bright points appear on the screen

- The picture of a display unit is composed of pixels. Tiny black points and/or bright points (pixels) on the screen do not indicate a malfunction.

Picture contours are distorted

- Change the current setting of “Cinema Drive” to other settings (page 24).

No colour on programmes

- Select “Reset” (page 24).

No colour or irregular colour when viewing a signal from the Y, P_B/C_B, P_R/C_R jacks of

- Check the connection of the Y, P_B/C_B, P_R/C_R jacks of  and check if each jacks are firmly seated in their respective jacks.

No picture from the connected equipment appears on the screen



- Turn the connected equipment on.
- Check the cable connection.
- Press  to display the connected equipment list, then select the desired input.
- Correctly insert the memory card or other storage device in the digital still camera.
- Use a digital still camera memory card or other storage device that has been formatted according to the instruction manual supplied with the digital still camera.
- Operations are not guaranteed for all USB devices. Also, operations differ depending on the features of the USB device and the video being played.

Cannot select the connected equipment on the menu or cannot switch the input

- Check the cable connection.

Sound

No sound, but good picture

- Press  +/- or  (Mute).
- Check if the “Speakers” is set to “TV Speakers” (page 26).

No sound or noisy sound

- Check if the TV system setting is appropriate (page 29).

Channels

Some channels are blank

- The channel is for scrambled/subscription service only. Subscribe to a pay TV service.
- Channel is used only for data (no picture or sound).
- Contact the broadcaster for transmission details.

General

The TV turns off automatically (the TV enters standby mode)

- Check if the “Sleep Timer” is activated (page 31).
- Check if the “Idle TV Standby” is activated (page 33).

Some input sources cannot be selected

- Select “Video Labels” and cancel “Skip” of the input source (page 31).

The remote does not function

- Replace the batteries.

HDMI equipment does not appear on “HDMI Device List”

- Check that your equipment is compatible with Control for HDMI.













Cannot select “Off” in “Control for HDMI”

- If you have connected any audio system that is compatible with Control for HDMI, you cannot select “Off” in this menu. To change the audio output to the TV speaker, select “TV Speakers” in the “Speakers” menu (page 26).

Lost password

- Select the “PIN Code” settings on the “Parental Lock” settings, then enter the following master password: 9999. This password clears your previous password and allows you to enter a new password (page 30).

Specifications

System	
Panel system	LCD (Liquid Crystal Display) Panel
TV system	B/G, I, D/K, M
Colour/video system	PAL, PAL60 (only video input), SECAM, NTSC4.43 (only video input), NTSC3.58
Channel coverage	B/G: VHF: E2 to E12/ UHF: E21 to E69/ CATV: S01 to S03, S1 to S41 I: UHF: B21 to B69/ CATV: S01 to S03, S1 to S41 D/K: VHF: C1 to C12, R1 to R12/ UHF: C13 to C57, R21 to R60/ CATV: S01 to S03, S1 to S41, Z1 to Z39 M: VHF: A2 to A13/ UHF: A14 to A79/ CATV: A8 to A2, A to W+4, W+6 to W+84
Sound output	KLV-40NX520/40CX420/40BX420/32NX520/32CX420/32CX320/32BX320/32BX311: 8 W + 8 W KLV-26CX320/26BX320/22CX320/22BX320: 5 W + 5 W
Input/Output jacks	
Antenna	75 ohm external terminal for VHF/UHF
 COMPONENT IN/  1	 COMPONENT IN Supported formats: 1080p, 1080i, 720p, 576p, 576i, 480p, 480i Y: 1 Vp-p, 75 ohms, 0.3V negative sync/Pb/Cb: 0.7 Vp-p, 75 ohms/Pr/Cr: 0.7 Vp-p, 75 ohms  1 Video input (phono jack)
 COMPONENT IN	Audio input (phono jacks)
 2	Video input (phono jacks)/Monitor out
 2	Audio input (phono jacks)
HDMI IN 1, 2* * Not available for KLV-32BX311	Video: 1080/24p, 1080p, 1080i, 720p, 576p, 576i, 480p, 480i Audio: Two channel linear PCM: 32, 44.1 and 48 kHz, 16, 20 and 24 bits, Dolby Digital  Analogue audio input (minijack) (HDMI IN 1 only) PC Input (see page 28)
	Audio output (phono jacks)
PC IN 	PC Input (D-sub 15-pin) (see page 28) G: 0.7 Vp-p, 75 ohms, non Sync on Green/B: 0.7 Vp-p, 75 ohms/ R: 0.7 Vp-p, 75 ohms/HD: 1-5 Vp-p/VD: 1-5 Vp-p
PC IN 	PC audio input (minijack)
	USB port
	Headphones jack

Model name		KLV-40NX520	KLV-40CX420	KLV-40BX420
Power and others				
Power requirements		110-240 V AC, 50/60 Hz		
Screen size (measured diagonally)	inches	40		
	cm (Approx.)	101.6		
Display resolution		1,920 pixels (horizontal) × 1,080 lines (vertical)		
Power consumption		Indicated on the rear of the TV.		
Dimensions (Approx.) (w × h × d)	with stand (mm)	1,000 × 642 × 260	992 × 635 × 250	988 × 632 × 250
	without stand (mm)	1,000 × 609 × 87	992 × 598 × 100	988 × 600 × 94
Mass (Approx.)	with stand (kg)	20.4	15.6	15.7
	without stand (kg)	17.8	13.6	13.6
Optional accessories	Wall-Mount Bracket	SU-WL50B		

Model name		KLV-32NX520	KLV-32CX420	KLV-32CX320	KLV-32BX320	KLV-32BX311
Power and others						
Power requirements		110-240 V AC, 50/60 Hz				
Screen size (measured diagonally)	inches	32				
	cm (Approx.)	80.1	80.0			
Display resolution		1,920 pixels (horizontal) × 1,080 lines (vertical)	1,366 pixels (horizontal) × 768 lines (vertical)			
Power consumption		Indicated on the rear of the TV.				
Dimensions (Approx.) (w × h × d)	with stand (mm)	812 × 534 × 250	800 × 532 × 220	800 × 528 × 220		
	without stand (mm)	812 × 502 × 87	800 × 497 × 97	800 × 496 × 91		
Mass (Approx.)	with stand (kg)	14.7	10.6	10.7		
	without stand (kg)	12.3	9.1	9.1		
Optional accessories	Wall-Mount Bracket	SU-WL50B				

Model name		KLV-26CX320	KLV-26BX320	KLV-22CX320	KLV-22BX320
Power and others					
Power requirements		110-240 V AC, 50/60 Hz			
Screen size (measured diagonally)	inches	26	22		
	cm (Approx.)	66.1	54.8		
Display resolution		1,366 pixels (horizontal) × 768 lines (vertical)			
Power consumption		Indicated on the rear of the TV.			
Dimensions (Approx.) (w × h × d)	with stand (mm)	672 × 459 × 220	668 × 455 × 220	551 × 402 × 215	551 × 393 × 215
	without stand (mm)	672 × 423 × 99	668 × 424 × 91	551 × 367 × 82	551 × 363 × 61
Mass (Approx.)	with stand (kg)	9.0	8.8	6.3	6.2
	without stand (kg)	7.5	7.3	5.7	5.6
Optional accessories	Wall-Mount Bracket	SU-WL100			

Design and specifications are subject to change without notice.



Customer support
<http://www.sony-asia.com/support>

Instructions on "Installing the Wall-Mount Bracket" are not supplied in the form of a separate leaflet with this TV. These installation instructions are included within this TV's instructions manual.



<http://www.sony.net/>